

# MINI-VERTICUS & VERTICUS THE NEXT GENERATION

INDUSTRIAL COMPRESSORS FOR AIR, NITROGEN AND RARE GASES



## MINI-VERTICUS & VERTICUS

### STATIONARY COMPRESSORS – REINVENTED

The new MINI-VERTICUS & VERTICUS Series set the standards of the future for stationary high-pressure compressor systems. The series combines the quality and reliability of the preceding stationary compressor series with an all-new design, B-CLOUD and B-APP smartphone connection, online air quality monitoring and outstanding ergonomic features.

The new, extremely compact MINI-VERTICUS benefits particularly from BAUER's signature design: numerous accessory models from the larger VERTICUS series, such as the B-CONTROL III control unit, are now also available for the MINI-VERTICUS.

With significantly lower-noise operation, outstanding ergonomic design and unparalleled user-friendliness.

- › 30 to 525 bar
- › 85 to 950 l/min
- › Available with open or soundproofed housing
- › For air, nitrogen and rare gases
- › Compressor or booster version





## ICONIC DESIGN

The groundbreaking design sets new standards. The sleek, bold lines of the new VERTICUS systems express their status as technology leaders in the field of stationary high-pressure compressors.



## ERGONOMIC

All the main operating elements and displays are conveniently located on the front for maximum ease of access and viewing. The front panel can be opened with a single movement to change the filter cartridge rapidly and conveniently.



## EVEN QUIETER

The sophisticated soundproofing concept has reduced the already low noise level still further. The motor is suspended in an optimised anti-vibration frame and incorporates a new type of high-efficiency hydro-damping system.



## CONTINUOUS AIR MONITORING

B-DETECTION PLUS is the new fully integrated gas measurement system that monitors the quality of the compressed breathing air. Automatic, continuous and outstandingly reliable.



## REMOTE ACCES

With the B-CONTROL MICRO and the B-CLOUD connection, you can monitor, analyse and optimise your system from a distance. Utilise the power of the cloud.



## B-CLOUD REMOTE ACCESS

B-CLOUD delivers a continuous real-time overview of all operating data from your BAUER compressor systems with B-CONTROL MICRO. If alerts or faults occur, you receive a push message on your smartphone if required.

## SETTING NEW STANDARDS FOR STATIONARY COMPRESSORS

IN A CLASS OF ITS OWN FOR DESIGN, ERGONOMICS AND FUNCTION



“Form follows function”, the famous principle of modern architecture, was our watchword for the development of the new design. It is reflected in even the tiniest detail.

All the main operating elements and displays are conveniently located for maximum ease of access and viewing.

The top front panel with the control unit can be raised for immediate access to the filter, so that changing the cartridge is simple and fast. As a further benefit, the filter housing is now located in the colder front area of the system and thus offers significantly extended cartridge life. The control unit is on the side of the system, likewise providing optimum cooling. The control panel can be fully extended for maximum convenience in operation.

The condensate tank, now with 40 per cent higher capacity, is located in the interior of the housing. The control unit displays a warning before the maximum condensate level is reached. The tank is easily emptied using a service valve.

B-DRAIN automatic condensate drain system has also been completely redesigned. The new system ensures that oil/water condensate is extracted at minimum loss of pressure and low noise. This saves wear on pressurised parts, extends their service life and increases the F.A.D. rate.

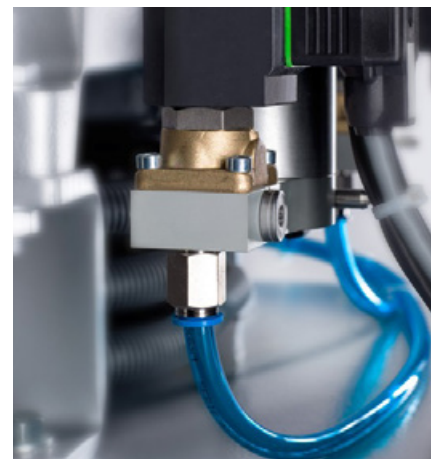

## THE G-SERIES – SPECIALISTS IN HELIUM AND ARGON COMPRESSION

### GAS COMPRESSION AND RECOVERY WITH MAXIMUM EFFICIENCY

The MINI-VERTICUS & VERTICUS units of the G series are specially optimised for operation with helium & argon. The special design with maximum gas tightness ensures minimum helium losses and best gas purity. Thanks to sophisticated and innovative high-pressure system technology, a leakage rate of less than 0.1 mbar l/s and thus an economic recovery and filling of noble gases is achieved.

The compressor block is designed specifically for rare gas processing and top efficiency. An array of design features effectively prevent leakage of the highly volatile gas, creating a closed gas cycle. The system features enclosed safety valves and gas-tight ferrule compression fittings on the high-pressure side. Gas from the crankcase ventilation system and the condensate valves is recovered and returned to the intake area.

The layout of the helium compression system is tailored to customers' needs. If required, the compressor, intake buffer tank and condensate reservoir can be supplied ex works as a turnkey plug-and-play solution, on a single shared base frame; alternatively, the components can be positioned on site to make the most of available space and assembled by BAUER's service team.

Helium can be used on request in final pre-delivery testing of these compressors.

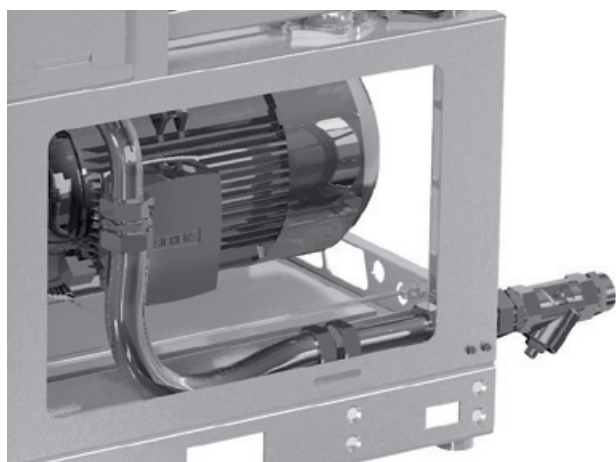

## THE NEW ACCESSORIES

### CUSTOMISING THE SYSTEM TO YOUR INDIVIDUAL NEEDS

The new MINI-VERTICUS & VERTICUS feature a wide range of accessories from standard models upwards.

However, we also offer you the opportunity to customise and extend your system in line with your individual requirements. Our comprehensive range of accessories opens up virtually unlimited possibilities.

For full details, see our separate “Accessories Brochure”.

- › **B-KOOL:** This fully integrated refrigeration dryer helps you to slash operating costs by significantly extending filter cartridge life. The purchase costs are soon recouped; from then onwards, you save money while helping to conserve the environment.
- › **P61/81 Purification Systems:** Depending on the application or filter cartridge type, these systems absorb, convert or extract moisture (H<sub>2</sub>O), oil and carbon monoxide (CO). Available as integrated or external systems.
- › **B-SECURUS Filter Cartridge Monitoring Unit:** Efficiently monitors filter cartridge saturation.
- › **Particle Filter:** An integrated particle filter is available for use in conjunction with P61 and P81 Purification Systems, ensuring effective protection against particle matter and offering reliable particle extraction that complies with ISO 8573 Class 2 standards.
- › **B-DETECTION PLUS s:** The new gas measurement system is also available with the same range of features as the B-DETECTION PLUS i as a standalone model for retrofitting.
- › **Oil Level Monitoring Function:** If the oil level reaches the minimum mark, this is indicated on the control display as a warning message. This option is highly recommended for compressor units in continuous operation.



## TECHNICAL DATA



Model	F.A.D. <sup>1</sup>			Max. operating pressure <sup>2</sup>		No. stages	Speed approx.	Motor output	Net weight approx.	
	l/min	m <sup>3</sup> /h	cfm	bar	psig				kg	lbs
<b>MINI-VERTICUS 90 - 365 bar</b>										
I 100-3-MV	85	5.1	3	365	5300	3	900	3	316	697
I 100-4-MV	125	7.5	4.4	365	5300	3	1270	4	324	714
I 120-4-MV	170	10.2	6	365	5300	3	1200	4	324	714
I 120-5.5-MV	215	12.9	7.6	365	5300	3	1470	5.5	333	734
I 12.14-7.5-MV	300	18	10.6	365	5300	4	1450	7.5	350	772
<b>VERTICUS 90 - 365 bar</b>										
I 15.1-7.5-V	340	20.4	12	365	5300	4	1050	7.5	384	847
I 15.1-11-V	420	25.2	15	365	5300	4	1320	11	402	886
I 150-11-V	500	30	18	365	5300	4	1230	11	402	886
I 180-15-V	610	36.6	21	365	5300	4	1320	15	416	917
<b>MINI-VERTICUS 350 - 420 bar</b>										
I 100-3-MV <sup>3</sup>	85	5.1	3	420	6100	3	900	3	316	697
I 120-5.5-MV <sup>3</sup>	190	11.4	6.7	420	6100	3	1350	5.5	333	734
<b>VERTICUS 350 - 525 bar</b>										
I 15.11-7.5-V	310	18.6	11	525	7600	4	960	7.5	408	900
I 15.11-11-V	420	25.2	15	525	7600	4	1320	11	426	939
I 18.1-15-V	510	30.6	18	525	7600	5	1490	15	468	1032



Model	F.A.D. <sup>1</sup>			Intake pressure	Max. operating pressure <sup>2</sup>		No. of stages	Speed approx.	Motor output	Net weight approx.	
	l/min	m <sup>3</sup> /h	cfm		bar	bar				psig	rpm
<b>MINI-VERTICUS - BOOSTER 90 - 365 bar</b>											
GIB 10.2-7.5-MV	290-385	17.4-23.1	10.2-13.6	2-3	365	5300	3	1350	7.5	351	774
GIB 12.2-5.5-MV	200-475	12-28.5	7-17	5-11	365	5300	2	1230	5.5	333	734
<b>VERTICUS - BOOSTER 90 - 365 bar</b>											
GIB 15.3-11-V	510-950	30.6-57	18-33.5	7-10	365	5300	2	1140/1440	11/15	413	911
GIB 15.41-15-V	430-830	25.8-49.8	15.2-29.3	2-4	365	5300	3	1350/1530	15	416	917



Model	F.A.D. <sup>1</sup>			Max. operating pressure <sup>2</sup>		No. of stages	Speed approx.	Motor-output	Net weight approx.	
	l/min	m <sup>3</sup> /h	cfm	bar	psig				rpm	kW
<b>MINI-VERTICUS 30 - 100 bar</b>										
B 12.4-4-MV	215	13	7.6	68	1000	3	1420	4	324	714
E 12.4-3-MV	170	10.2	6	85	1230	3	1150	3	316	697
E 12.4-4-MV	215	13	7.6	85	1230	3	1420	4	324	714
E 120-4-MV	215	13	7.6	100	1450	3	1420	4	324	714

1 Volume flow rate in accordance with ISO 1217. Different ambient conditions will result in differing performance values. Values are valid for 50 Hz.

2 Max. operating pressure = max. pressure setting for safety valve; shutdown pressure is lower.

3 Not suitable for nitrogen.

Dimensions L x W x H

MINI-VERTICUS: 1195 x 802 x 1372 mm

VERTICUS: 1195 x 802 x 1525 mm

## TECHNICAL DATA

HE

Model	F.A.D. <sup>1</sup>			Max. operating pressure <sup>2</sup>		No. of stages	Speed approx.	Motor-output	Net weight approx.	
	l/min	m <sup>3</sup> /h	cfm	bar	psig				kg	lbs
<b>MINI-VERTICUS 90 - 230 bar</b>										
G 120-4-MV	105	6.3	3.7	230	3350	3	900	4	330	730
G 120-5.5-MV	140	8.4	4.9	230	3350	3	1250	5.5	340	750
<b>VERTICUS 150 - 230 bar</b>										
G 15.2-15-V	420	25.2	14.8	230	3350	4	1320	15	425	930
<b>VERTICUS 90/200 - 350 bar</b>										
G 15.1-7.5-V	240	14.4	8.5	350	5100	4	880	7.5	400	880
G 15.1-11-V	320	19.2	11.3	350	5100	4	1230	11	415	910
G 18.1-15-V	420	25.2	14.8	350	5100	5	1490	15	430	950

AR

Model	F.A.D. <sup>1</sup>			Max. operating pressure <sup>2</sup>		No. of stages	Speed approx.	Motor-output	Net weight approx.	
	l/min	m <sup>3</sup> /h	cfm	bar	psig				kg	lbs
<b>MINI-VERTICUS 90 - 230 bar</b>										
G 100-3-MV	90	5.4	3.2	230	3350	3	900	3	320	710
G 120-4-MV	130	7.8	4.6	230	3350	3	900	4	330	730
G 120-5.5-MV	180	10.8	6.4	230	3350	3	1250	5.5	340	750
<b>VERTICUS 90 - 230 bar</b>										
G 15.2-11-V	370	22.0	12.9	230	5100	4	880	11	415	910
<b>VERTICUS 90/200 - 350 bar</b>										
G 15.1-11-V-AR	310	18.6	10.9	350	5100	4	880	11	415	910
G 18.1-11-V	410	24.6	14.5	350	5100	5	1100	11	420	925

1 Volume flow rate in accordance with ISO 1217, valid for argon or helium.  
Different ambient conditions will result in differing performance values. Values are valid for 50 Hz.

2 Max. operating pressure = max. pressure setting for safety valve; shutdown pressure is lower.

Compressor dimensions L x W x H  
MINI-VERTICUS: 1195 x 802 x 1372 mm  
VERTICUS: 1195 x 802 x 1525 mm  
G18.1-xx-V: 2350 x 1020 x 1900 mm

**BAUER KOMPRESSOREN GmbH**

Stäblistr. 8

81477 München

Tel. +49 (0) 89 78049-0

Fax +49 (0) 89 78049-167

[info@bauer-kompressoren.de](mailto:info@bauer-kompressoren.de)

[bauer-kompressoren.de](http://bauer-kompressoren.de)



**MINI-VERTICUS & VERTICUS IND EN**

N42254

02.2025

Subject to technical change without notice